

# Intellex FMR-5000 Reader

Intellex Corporation offers break-through performance with its standards-compliant extended capability RFID readers



The FMR-5000 can read EPC-compliant passive C1G2 tags and next-generation battery-assisted Class 3 tags

The Intellex FMR-5000 multi-protocol RFID reader provides extended capabilities with industry-leading range and read/write reliability. The FMR-5000 reader's advanced design ensures easy field upgradeability to new and enhanced features, as well as future industry standards. The reader's intuitive graphical user interface offers exceptional ease of use.

The multi-user/multi-tasking software supports up to seven simultaneous sessions so that multiple applications can interact with the reader. This feature greatly simplifies both system and application design.

The FMR-5000's flexible network connectivity and discovery capabilities enable easy integration into existing networks. Its built-in web server provides reader status reporting, remote reader configuration, and reader firmware upgrades. It also provides web-based tag inventorying, tag memory reading/writing, and tag commissioning. To aid setup and troubleshooting, the FMR-5000 provides a spectral monitoring display via a web page or as an XML data stream. It also allows for the hosting of custom web pages and Java applications.

The FMR-5000 reader's robust design withstands harsh environments such as warehouse and industrial areas. It can be configured with up to four antenna pairs and interfaces to the network using Ethernet.

## FEATURES

### Advanced Design

- High sensitivity receiver
- Adaptive signal processing and noise reduction
- Advanced tag-singulation algorithms
- Multiple session support
- Reader discipline
- Triggers and alarms
  
- Web and Java application hosting

### Standards Compliance

- Intellex Class 3 operation
- EPCglobal Class 1 Gen 2

### Built-in Application-specific Security

### Communication Capability

- Native web capability
- Ethernet
  
- GPIO ports
  
- RS-232 serial

## BENEFITS

- High read/write accuracy in very harsh, RF unfriendly environments
- Exceptional tag inventorying and memory read/write reliability in real world environments
  
- Enables more efficient tag search and access
- Supports multiple simultaneous applications on different interface ports
- Allows applications to efficiently share the RF environment
- Supports both external and data driven triggers
- GPIO pins can be programmed to control external devices
- Allows for easy customization and standalone operation

- Battery-assisted passive technology
- Global interoperability

- Allows selected access to tag memory on Intellex tags (protects data integrity)

- Real-time asset visibility from any place in the world
- Remote reader management
- Easy integration into existing network
- Integrates external sensors and peripherals for intelligent control of assets (e.g. optical triggers, light stacks, PLCs)
- Network configuration and restore factory defaults

## SPECIFICATIONS<sup>1</sup>

<b>Physical Characteristics</b> Dimensions Weight Visual Status Indicators	7.5" x 12" x 2.6" (19,1 cm x 30 cm x 6,6 cm) (includes mounting plate with four 6,5 mm mounting holes) 6.1 lbs (2,8 kg) LEDs for power (green), activity (yellow) and software on (red)
<b>Connectivity</b> Network External Interfaces RF Connectors Antenna Ports Power Supply	10/100 BaseT Ethernet RJ45 GPIO Port (4 input, 4 output ports) 16 pin connector; RS-232 Serial DB9 Female Reverse-TNC 4 transmit ports, 4 receive ports +24 V DC @ 1.5 amps
<b>Environmental</b> Enclosure Protection Temperature Standards Operating Storage Humidity Standard Vibration Standard	IP54 IEC 60068-2-1, IEC 60068-2-2, IEC 60068-2-14 32° to 131°F (0° to +55°C) -4° to 158°F (-20° to +70°C) IEC 60068-30/78, 5-95% non-condensing IEC 60068-2-6
<b>Compliance/Certifications</b> EMC Agency Listings RoHS	FCC Part 15 Class B, EN55022 Class B, EN55024, CISPR 22 Class B UL 60950, cUL C22.2 No. 60950-00, TUV EN60950, CE Restriction of Hazardous Materials Compliance
<b>Hardware/OS And F/W Management</b> Firmware Upgrade Receiver Sensitivity Tag Protocol IP Addressing Host Interface Protocols Embedded Java Application Hosting Method Radiated Power Output Number of Channels	Web-based and remote firmware upgrade capabilities -105 dBm EPC C1G2 (Read, Write), Class 3 (Read, Write) Static and dynamic XML Java 1.4 CDC Foundation Subset Frequency Hopping Spread Spectrum (FHSS); required for US; not required for Europe and India US: 4 W (EIRP); Europe and India: 2 W (ERP) US: 50; Europe and India: 4

1. Intellex reserves the right to change product information and specifications without notice.

## ORDERING INFORMATION

<b>Part Number</b> FMR-5000 FMR-5000-EU FMR-5000-IN	<b>Description</b> FMR-5000 RFID Reader; North America 902 – 928 MHz frequency band FMR-5000 RFID Reader; Europe 865.6 – 867.6 MHz frequency band FMR-5000 RFID Reader; India 865 – 867 MHz frequency band
--	---

## DIMENSIONS

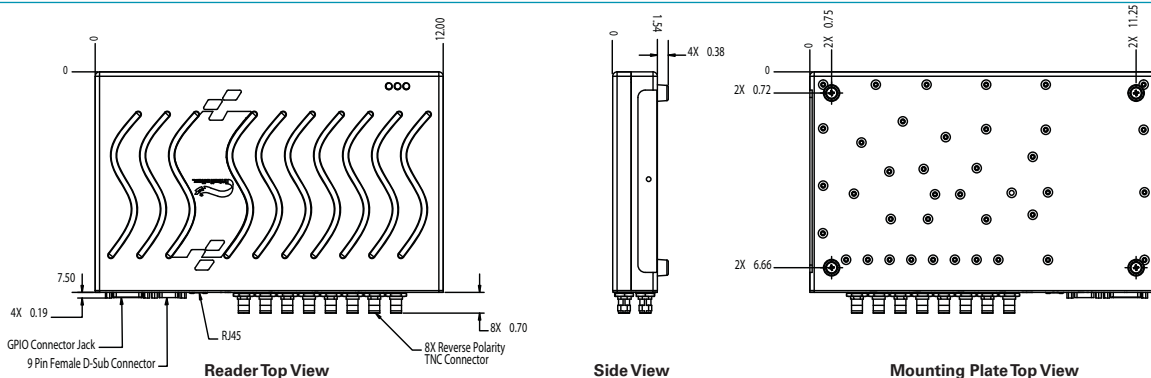

Note: All dimensions are in inches (mm)

© 2008 Intellex Corporation. All rights reserved. Intellex and The Intelligent RFID Platform Company are trademarks of Intellex Corporation. The Intellex logo is a registered trademark of Intellex Corporation.

05-00075-004 (10/08)



Intellex Europe

Binnenweg 117, 2570 Duffel, Belgium  
 Phone +32 15 30 80 90  
 Fax +32 15 30 80 99  
 emea@intellex.com  
 www.intellex.com